

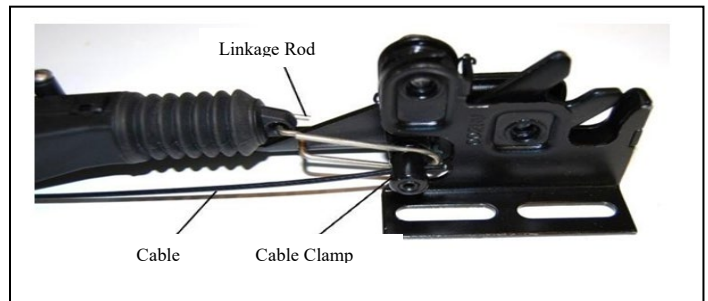

PL9000 – Power Pop Universal Keyless Entry System Tonneau Cover Installation Instructions

- 1) Replace both of the existing rotary latches on the tonneau cover with the new supplied power adaptable rotaries. Install both Actuator Brackets with the supplied Bracket Bolts. Install both Linkage Rods by sliding them into the grooves in the rotary latch cable clamps, then hook the end of the linkage rods through the holes in the end of the Actuators and bolt the Actuators to the Actuator Brackets with the supplied Actuator Screws (there is a tab on the Actuator Bracket that only allows the Actuator to be mounted on one way). You may also need to install new strikes which are also supplied.

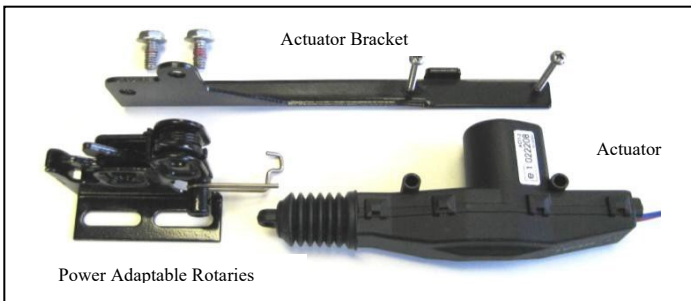
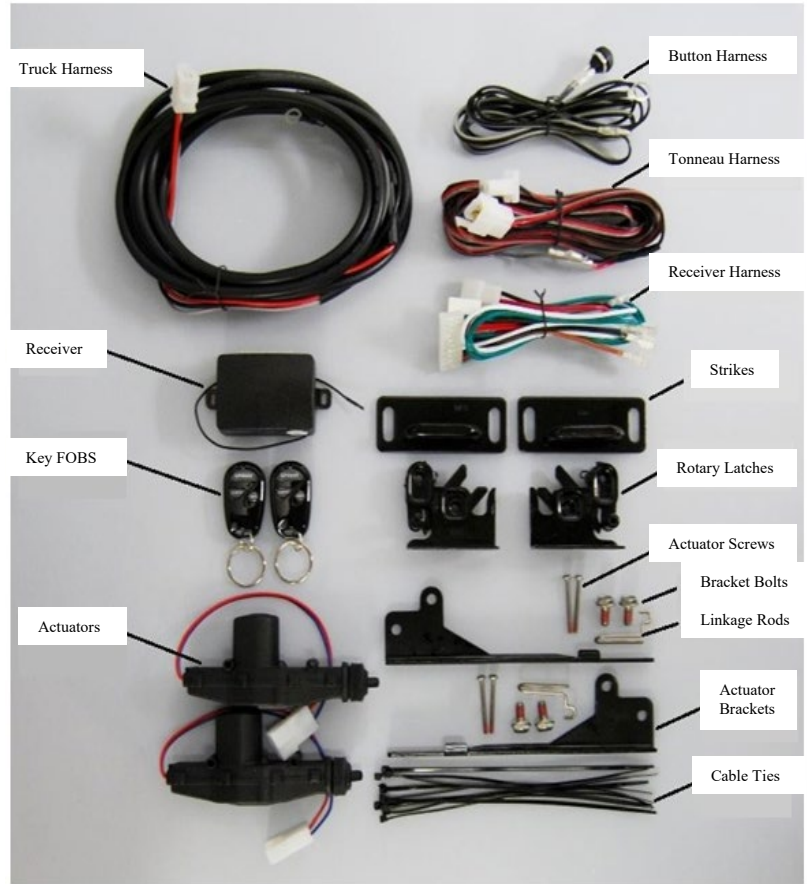

- 2) Mount Keyless Receiver to tonneau cover centered between the rotary latches. Be sure to use proper length screws and **only screw into the thick portions of the tonneau as to not protrude the outer surface of the tonneau cover.**

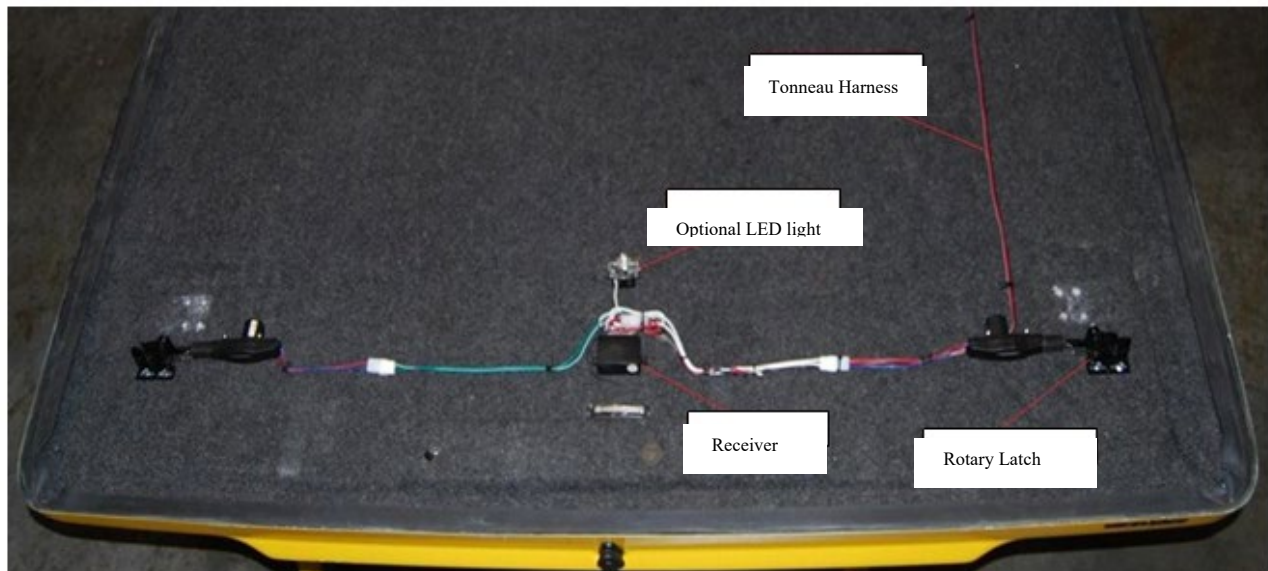

3) Connect receiver actuator outputs to the actuators and bundle up and wire tie any excess wire length.

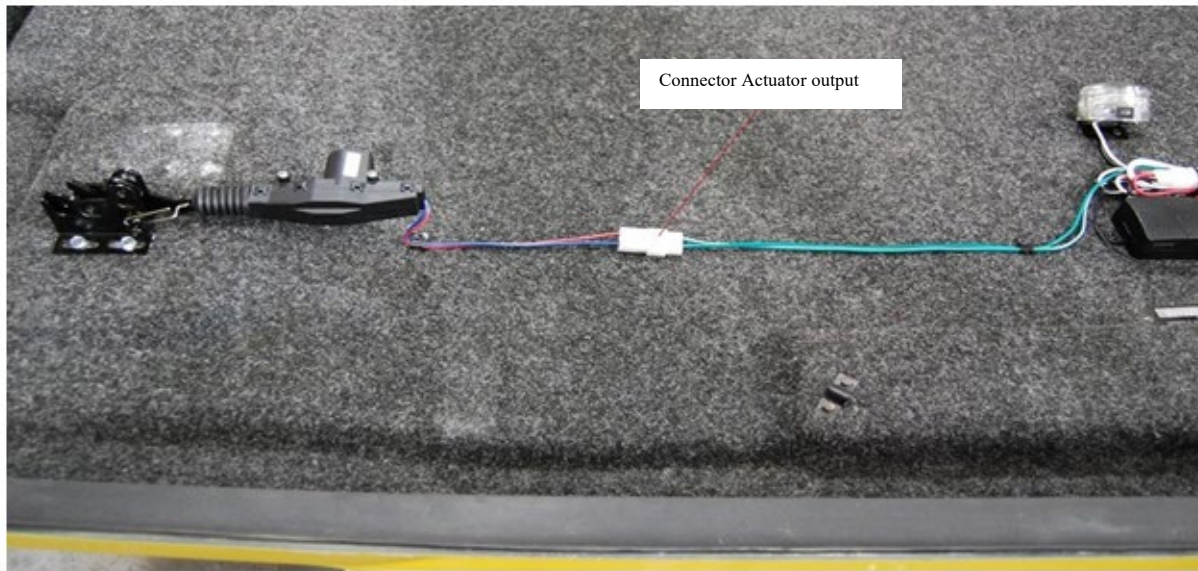

4) Connect Tonneau Harness to the Receiver. If using the optional in cab remote button, connect the gray wire from the Tonneau Harness to the gray wire on the Receiver. Route the tonneau Harness wire up the center of the tonneau cover then over to the driver side front corner of the box. Mount the harness with supplied Cable Clamps and screws or under the carpeted head liner. Leave the end of the harness accessible to be able to later connect it to the Truck Harness.

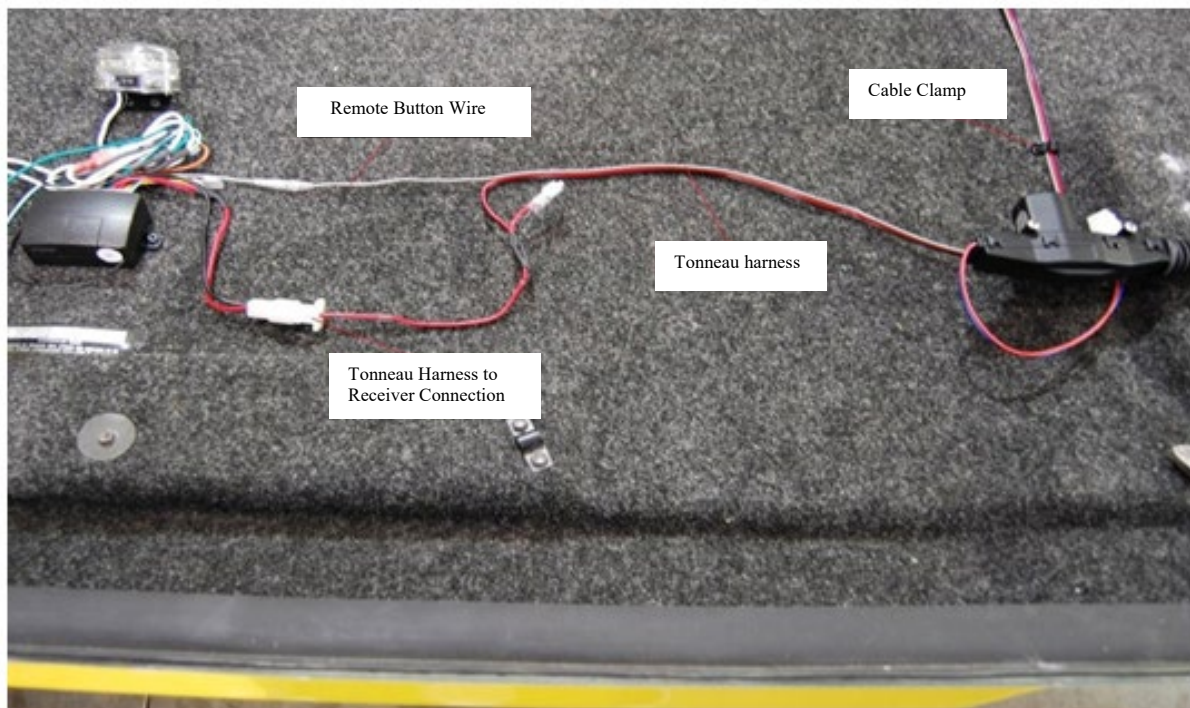

- 5) Connect the optional 12 volt LED light (01355) to the timed light outputs on the Receiver, black to black and white to white. Mount light where desired.

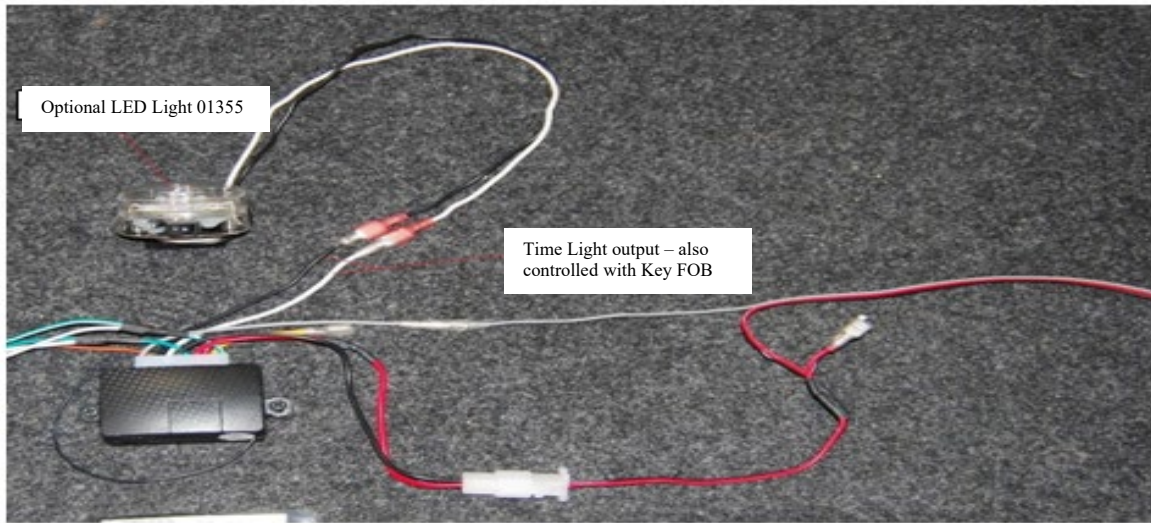

- 6) Attach the Truck Harness to the Tonneau Harness with the one way plug in the front corner of the tonneau. Route the Truck Harness down along the truck frame and up into the engine compartment. Fasten the Truck Harness securely with wire ties along the frame. Bundle and wire tie any extra wire from the Truck Harness securely up under the hood. Connect the red wire from the Truck Harness to any constant 12 volt power supply; most trucks have an auxiliary power terminal for such accessories. Be sure to properly ground the black wire.

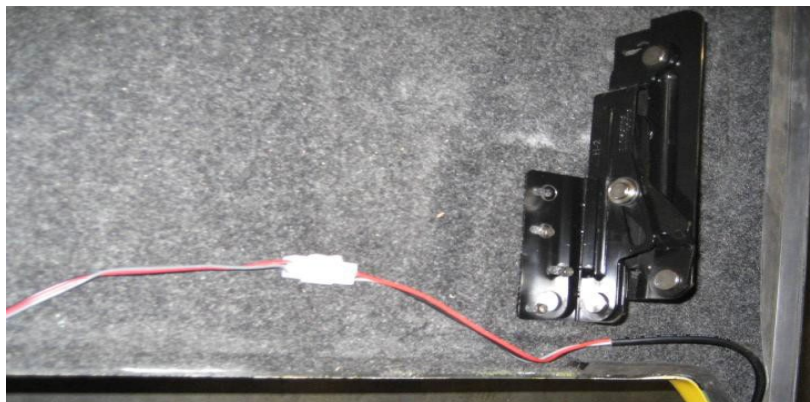

- 7) If using the in cab remote button option, route the Button Harness into the cab of the truck through an existing grommet. Drill a 1/2" hole in the desired location of the button and mount it through the hole. Attach the black wire to a good ground and plug the gray wire from the Button Harness into the gray wire on the Truck Harness.

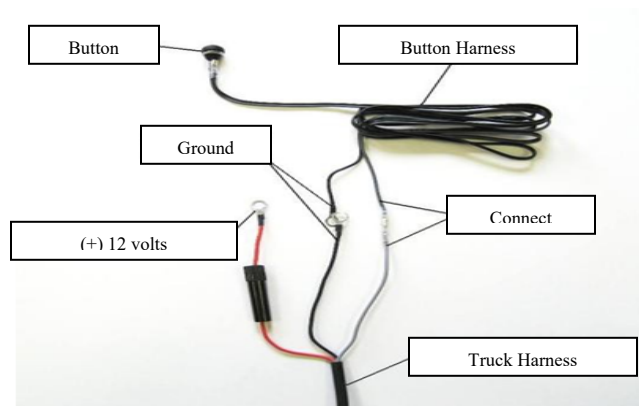

Keyless Entry Instruction / User' Guide

1. (+) input for system disable.
2. Ap1 is (-, +) input to active program.
The system would pause to work if triggered 8 times continuously in 30s, and start to work again 30s later.
3. Ap2 is the new added (-, +) input to activate program which can be controlled by transmitter.
Press the button of Unlcok, Ap2 begins to work,
Press the button of Lock/Off, Ap2 stops.
4. The active and negative startups of Ap1 and Ap2 can be switched by JS1 and JS2.
5. Press button to Unlock, the central door locking system and Ap2 would begin to work, and the flash lights would be on for 2 minutes.
6. Press the button of Lock/Off, Ap2 stops, and flash lights turn off.
7. Press the button of Light, the flash lights would be on for 5 minutes.
8. Code Learning:
Press the programming button for 3 times, LED lights would be on. If there is no transmitter to be learned, the LED will turn off and quit the learning mode.
After learning the first transmitter, the lights would be on, and would turn off and quit the learning mode if not learning in 10 seconds.
After learning the second transmitter, the lights would be on, and would turn off and quit the learning mode if not learning in 10 seconds.
After learning the third transmitter, the lights would turn off.
9. Press the button of Unlock for 8 times within 30 seconds, the system would pause to work and start again in 30 seconds (it's the same if press the button of Lock/Off and Light alternatively for 8 times within 30 seconds).
10. The function of transmitter is as follows.

Wiring Diagram

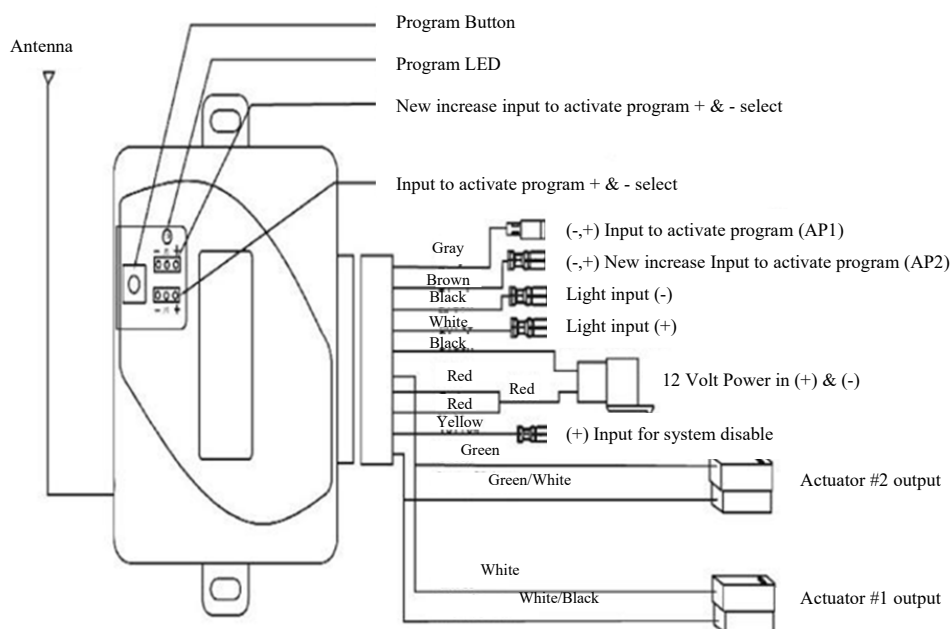

VEHICLE WIRING CHART

Pop N Lock

(All wire color information is for reference only and may vary by vehicle)

Please verify with a test light

If you have trouble locating the lock and unlock wires, test all the wires with a test light that are inside the rubber boot that runs between the door and the cab of the truck to find correct wire colors.

MAKE	MODEL	YEARS	WIRE COLOR		WIRE LOCATION (*Note 1)
			LOCK	UNLOCK	
Chevy/GMC	Silverado/Sierra	99-02	Tan	Gray	Driver Side Kick Panel Or Just Below Driver Side Fuse Block
Chevy/GMC	Silverado/Sierra S-10/Sonoma Colorado/Canyon	03-06	Tan	Gray	Driver Side Door Between Switch and Lock Actuator (*Note 2)
Chevy/GMC	Silverado/Sierra S-10/Sonoma Colorado/Canyon	07+	Tan	Blue	Driver Side Door Between Switch and Lock Actuator (*Note 2)
Chevy/GMC Crew Cab	Silverado/Sierra S-10/Sonoma Colorado/Canyon	03+	Tan	Gray	Under the sill plate in the wiring harness that goes under the driver's side seat.
Chevy/GMC	Full Size	88-98	Tan	Gray	Driver Side Kick Panel
Chevy/GMC	S-10	94-02	Tan	Gray	Driver Side Kick Panel
Ford	Sport Trac	01-06	Pink	Pink/Black	Passenger Kick Panel (*Note 5)
Ford	Sport Trac	07+	Gray/Brown	Purple/Gray	Passenger Kick Panel (*Note 5)
Ford	F-150 / F-250 / F-350	97-03	Red/Green	Pink/Orange or Red/Orange	Above Steering Column or Driver Side Kick Panel (*Note 5)
Ford	F-150 / F-250 /F-350	04-07	Pink/Black	Pink/Orange or Red/Orange	Above Steering Column or Drivers Side Kick Panel (*Note 5)
Ford	F-150/F-250/F-350	08	Gray or Gray/Tan	Purple or Purple/Gray	Above Steering Column or Drivers Side Kick Panel (*Note 5)
Ford	F-150/F-250/F-350	09+	Gray/Brown	Lt. Blue/Lt Green or Purple/gray	Above Steering Column or Drivers Side Kick Panel (*Note 5)
Ford Crew Cab	F-150/F-250/F-350	09+	Gray/Brown	Purple/Gray	Drivers side Sill Plate (*Note 8)
Ford	Ranger	99-07	Pink/Black	Pink/Orange	Passenger Side Kick Panel (*Note 5)
Ford	Ranger	08+	Blue/Green or White/Purple	Gray/Black or Gray/Purple	Passenger Side Kick Panel (*Note 5)
Dodge	Dakota	97-04	Orange/Black	Blue	Driver Side Kick Panel (*Note 5)
Dodge	Dakota	05+	Lt .Green/Blue	Purple/Black	Driver Side Kick Panel Or Passenger Side Kick Panel (*Note 5)
Dodge	Ram 1500	94-03	Tan/Pink	Blue	Driver Side Kick Panel (*Note 5)
Dodge	Ram 1500/2500 3500	04-08	Brown/Orange or Tan/Green	Lime Green	Driver Side Kick Panel (*Note 5)
Dodge	Ram 1500/2500 3500	09+	Orange/Gray or Tan/Green	Lime Green or Tan/White	Driver Side Kick Panel (*Note 5)
Dodge	Ram 2500 / 3500	94-03	Orange/Black	Pink/Violet	Driver Side Kick Panel (*Note 5)
Honda	Ridgeline	06+	Yellow/black	Yellow/green	Driver's Side Kick Panel(*Note 6 & 9)
Mazda	B-Series	99+	Pink/Black	Pink/Orange	Passenger Side Kick Panel (*Note 5 & 9)
Nissan	Titan	04+	Brown or Green/Yellow	Green/Red or Purple	Driver Side Kick Panel (*Note 5 & 9)
Nissan	Frontier	95-04	Brown	Green/Red	Driver Side Kick Panel (*Note 5 & 9)
Nissan	Frontier	05+	Purple	Green	Driver Side Kick Panel (*Note 5 & 9)
Toyota	Tacoma/Regular cab Access cab	98-06	Blue	Blue/White	Driver Side Kick Panel(*Note 4 & 9)
Toyota	Tacoma/Double cab	98-06	Blue/Pink	Blue	Driver Side Kick Panel(*Note 4 & 9)
Toyota	Tacoma/Double cab Access Cab	07+	Blue/Black	Blue/Red	Driver Side Kick Panel(*Note 7 & 9)
Toyota	Tundra	99-03	Pink/Black	Red/Orange	Driver Side Kick Panel (*Note 5 & 9)
Toyota	Tundra	04+	Pink/Black or Blue/White	Red/Orange or Black/Yellow	Driver Side Kick Panel(*Note 3 & 9)
Toyota	Tundra/Crew Max Double Cab	07+	White	Blue	Driver Side Kick Panel –Top Blue Plug (*Note 5 & 9)
Toyota	Tundra/Double cab	04+	Blue/Red	Blue/Black	Driver Side Kick Panel (*Note 5 & 9)

*See Notes Following Page



VEHICLE WIRING CHART

Pop N Lock

(All wire color information is for reference only and may vary by vehicle)

Please verify with a test light

If you have trouble locating the lock and unlock wires, test all the wires with a test light that are inside the rubber boot that runs between the door and the cab of the truck to find correct wire colors.

To Test With a Test Light: Ground the test light to good conducting ground and probe the wire to be tested by piercing the wire case to connect to the copper wire inside. Hit the lock button to see if the test light lights up. If so this is the lock wire. Do the same with the unlock wire to verify the correct wire.

Note 1:

If the wiring is connected in the driver's side kick panel, the Handle will lock/unlock with the driver's door. If you prefer the Handle to lock/unlock with the passenger door, on some models the wiring may be connected into the passenger side kick panel using the same color wiring. If the same colors can't be found, use a test light to find the passenger side colors.

Note 2:

On the CHEVY/GMC 03+ Two door or Extended Cab Models (if not using a relay harness) it is necessary to remove the driver's side door panel and attach the lock and unlock wires directly to the wires of the door lock actuator inside the door. Once the door panel is removed, you will need to remove the driver's side kick panel and fish the harness wires through the rubber boot that runs between the door and the cab of the truck and into the door. Use the supplied Wire Taps to attach to the specified wires directly under the truck's door lock switch and test the locks. If the truck locks operate opposite the lid lock, reverse the leads connected.

Note 3:

Some 04 Toyota Tundra models used blue/white instead of pink/black for the lock wire and black/yellow instead of red/orange for the unlock wire.

Note 4:

Make sure the key is out of the ignition when testing this model; as the doors will automatically unlock when trying to lock.

Note 5:

If you have trouble locating the lock and unlock wires, test all the wires that are inside the rubber boot that runs between the door and the cab of the truck. Once you locate them you can follow them to a location that makes tapping to the wires easier. This works on most models except 03+ G.M.

Note 6:

On the Honda Ridgeline the lock and unlock wires are located in the fuse panel down by the driver's side kick panel. The yellow/black(lock) and the yellow/green(unlock) wires are in the small green plug that is located at the bottom front side of the fuse box. A small hole may need to be drilled in the side of the bed rail near the top rear on the driver's side of the bed to access the rear tail light compartment to attach the brake light and power lock wiring.

Note 7:

On the 07+ Double Cab Tacoma the lock wire is located in the 10 pin plug, pin#9, Blue/Black wire. The unlock wire is located in the 12 pin plug, pin#10, Blue/Red wire; both plugs are hanging loose in the driver side kick panel.

Note 8:

On the Ford 09+ crew cabs the lock/unlock wires are located under the drivers side step plate. Look for the wires just before the pillar between the doors. Gray/Brown for Lock and Purple/Gray for unlock, there are multiple and different size purple /gray wires – use the largest gauge.

Note 9:

On some models the factory keyless system may be programmed to re-lock the truck doors after 1 or 5 minutes if the truck is unlocked and the door are not physically opened. Please refer to the user's manual or contact your local dealer if you require a change to the factory programming.

Please visit www.PopandLock.net for the latest wiring Info.

For Technical Support, Monday–Friday, 8:00 am to 5:00 pm CST:

1-800-342-5911



LIMITED WARRANTY TERMS AND CONDITIONS

- (1) **Installation.** Pop & Lock™, LLC (and Pop & Lock™ Corporation) is not responsible for installing the Pop & Lock™ or for the harm suffered by any person as a result installing it.
- (2) **Warranties.**
- Customer acknowledges that it is unreasonable to believe that any device whatever will prevent a theft in the case of every attempt and that the most that can be expected from a so-called anti-theft or security device is that it will deter many thieves.
 - POP & LOCK™ LLC. (and Pop & Lock™ Corporation) MAKES, AND CUSTOMER RECEIVES, NO WARRANTY, EXPRESSED OR IMPLIED, EXCEPT THE WARRANTIES OF TITLE TO THE POP & LOCK™ AND THEIR MERCHANTABILITY, PARTICULARLY NO WARRANTY OF FITNESS FOR A PARTICULAR USE OR PURPOSE OR AGAINST INFRINGEMENT.**
 - As Customer's only remedy, Pop & Lock™, LLC (and Pop & Lock™ Corporation) will repair or replace, at its option and without charge, any lock that is defective in material or workmanship when received by Customer and is returned to Pop & Lock™ LLC (and Pop & Lock™ Corporation), FOB Pop & Lock™ Corporation's offices, within one
 - year after it's receipt by the Customer. Pop & Lock LLC will ship all replacement, or repaired, Locks to Customer, FOB Pop & Lock™'s shipping point.
 - Factory support is only available for Pop & Lock™ products purchased as **new** through an Authorized Pop & Lock™ dealer.
Please Note: Pop & Lock™ Products purchased on auction sites such as Amazon, Ebay and Craigslist, to name a few, will not be covered under factory warranty under any circumstance. Pop & Lock™, LLC (and Pop & Lock™ Corporation) is unable to verify whether products sold through Auction Sites are new, used, or refurbished, and as such, Pop & Lock, LLC (and Pop & Lock™ Corporation) is unable to warranty such purchases. Pop & Lock, LLC advises using extreme caution when buying through auction sites as you'll be doing so at your own risk.
- (3) **No Liability.** Pop & Lock™ Corporation is not liable for any loss or damage claimed by Customer or any third person to have been suffered or incurred as a result or, or related to, the Locks purchased under this Agreement, regardless of the circumstances or form of action, except any bodily injury or death for which Pop & Lock™ is liable under products-liability law. Without limiting the generality of the foregoing, in no event will Pop & Lock™ LLC be liable to Customer for any indirect, special, or consequential damages, regardless of the circumstances or the cause of action, particularly not for the value of a vehicle, or any other money damages in the event that a tailgate is stolen either notwithstanding the use of a Pop & Lock™ or when it has been returned for repair or replacement.

END OF TERMS AND CONDITIONS

POP & LOCK LLC 1271 CONTRACT DRIVE GREEN BAY, WI USA 54304

*Additional Install Instructions and answers to technical questions can be found on our website at www.popandlock.net or by calling
Technical Support 1-800-342-5911 option 1
Monday – Friday 8:30am to 4:30pm CST*

Pop and Lock's limited warranty expires one (1) year after date of purchase.

Proof of purchase is required for warranty claims. Please submit a scanned copy or electronic image/photo of your receipt through any of the following methods:

- E-mail: technicalsupport@popandlock.net
- Fax: 855-491-5911
- Mail: 1271 Contract Ave, Green Bay, Wisconsin (USA) 54304

Please be sure to include:

- Name, address and phone number
- Model and year of truck
- Model/Part number of the lock
- Brief description of the problem

