

Model PL8100
1988-1998 Chevy Silverado
1988-1998 GMC Sierra
1997-2015 Dodge Dakota
2006-2015 Mitsubishi Raider

POWER TAILGATE LOCK INSTRUCTIONS

Layout – Rear View:

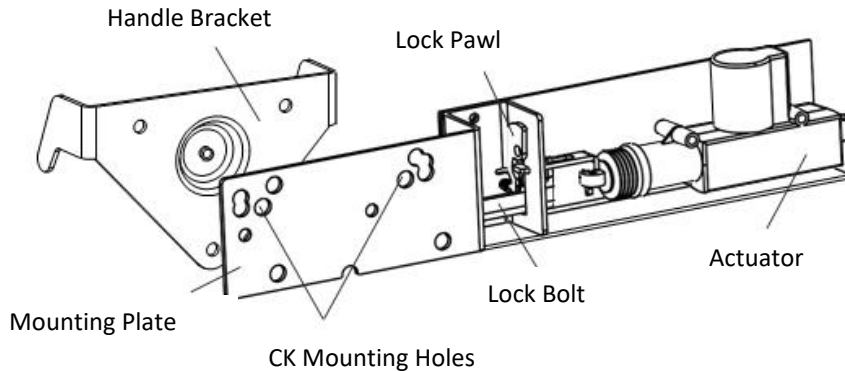

Parts Included:

Power Tailgate Lock Unit
Short Wiring Cable
Long Wiring Cable
Cable Ties
Blue Connector Taps

Tools Required:

T-40 Torx Driver
Pliers

Installation:

1. Remove the black plastic bezel. Squeeze the top edge of the bezel down until it releases. Tilt the bezel away at the top and pull it up to release the bottom.
2. Lower the tailgate – FROM THIS POINT UNTIL COMPLETION DO NOT CLOSE THE TAILGATE.
3. Release the rod ends from the scissor links, remove the three screws holding the handle bracket and lift it out of the tailgate.
4. Test the system by bolting the POWER LOCK to the handle bracket with two screws as shown, connect it to the short and the long wiring harness and take it forward into the cab to test wire it.
5. **WIRING:** Remove the driver's side kick panel and locate the harness leading to the driver's side door. Locate the **gray wire** and the **tan wire**. Attach the blue connector taps to them and squeeze them shut with the pliers.
6. Connect the long wiring harness to the blue connector taps and test the system. Lock and unlock the doors using the power door lock switch. The locking mechanism of the power tailgate lock should lock and unlock the handle. The Lock Pawl should drop into the notch of the Lock Bolt to hold it in the locked position. Reverse the wiring if the operation is out of phase. You can now unplug the wires from the blue connector taps.
7. Feed the round bullet connectors on the end of the short wiring cable into a drain hole at the bottom of the tailgate and up the tailgate to the handle opening. Connect them to the wires of the power tailgate lock.
8. Place the power tailgate lock inside the tailgate with the actuator on the driver's side. To get in, you will have to insert it with the actuator and the mounting plate facing up. Once inside, flip it over 180° so that the mounting plate is flush with the rear wall of the tailgate.
9. Replace the handle in the tailgate. Align the holes of the handle with the specified holes (see photo above) for the power lock, and the tailgate and reinstall the three mounting screws.
10. Connect the rod ends into the scissor links and snap the plastic bezel into place.
11. Route the end of the short cable from the tailgate between the bumper and the truck bed.
12. Connect the short wire harness to the long wire harness. Locate the connector so that you can reach it to remove the tailgate. Coil and tie the extra length of the short wiring harness inside the tailgate. Don't attach it to the truck.
13. Route the long wire harness along the frame rail and the existing wiring on the driver's side of the truck. Use cable ties to attach the harness to the existing wiring underneath the truck. Follow the existing wiring under the cab and up the firewall to the grommet at the hood-release cable.
14. Pull the wires through the grommet and lead them to the blue connectors you attached to the wiring in Step 5. The system is now fully installed. CLOSE THE TAILGATE. Perform a final check and reverse the wires if necessary.

LIMITED WARRANTY TERMS AND CONDITIONS

- (1) **Installation.** Pop & Lock™, LLC (and Pop & Lock™ Corporation) is not responsible for installing the Pop & Lock™ or for the harm suffered by any person as a result installing it.
- (2) **Warranties.**
- Customer acknowledges that it is unreasonable to believe that any device whatever will prevent a theft in the case of every attempt and that the most that can be expected from a so-called anti-theft or security device is that it will deter many thieves.
 - POP & LOCK™ LLC. (and Pop & Lock™ Corporation) MAKES, AND CUSTOMER RECEIVES, NO WARRANTY, EXPRESSED OR IMPLIED, EXCEPT THE WARRANTIES OF TITLE TO THE POP & LOCK™ AND THEIR MERCHANTABILITY, PARTICULARLY NO WARRANTY OF FITNESS FOR A PARTICULAR USE OR PURPOSE OR AGAINST INFRINGEMENT.**
 - As Customer's only remedy, Pop & Lock™, LLC (and Pop & Lock™ Corporation) will repair or replace, at its option and without charge, any lock that is defective in material or workmanship when received by Customer and is returned to Pop & Lock™ LLC (and Pop & Lock™ Corporation), FOB Pop & Lock™ Corporation's offices, within one
 - year after it's receipt by the Customer. Pop & Lock LLC will ship all replacement, or repaired, Locks to Customer, FOB Pop & Lock™'s shipping point.
 - Factory support is only available for Pop & Lock™ products purchased as **new** through an Authorized Pop & Lock™ dealer.
Please Note: Pop & Lock™ Products purchased on auctions sites such as Craigslist etc. will not be covered under factory warranty. Products purchased from an authorized dealer as "new" on websites such as Amazon and Ebay must follow their website warranty policy, process and procedures. Pop & Lock™ Products sold as "used", "refurbished", "open box" etc., cannot be verified by Pop & Lock™, LLC (and Pop & Lock™ Corporation), and as such, Pop & Lock, LLC (and Pop & Lock™ Corporation) is unable to warranty such purchases. Pop & Lock, LLC advises using extreme caution when buying through auction sites as you'll be doing so at your own risk.
- (3) **No Liability.** Pop & Lock™ Corporation is not liable for any loss or damage claimed by Customer or any third person to have been suffered or incurred as a result or, or related to, the Locks purchased under this Agreement, regardless of the circumstances or form of action, except any bodily injury or death for which Pop & Lock™ is liable under products-liability law. Without limiting the generality of the foregoing, in no event will Pop & Lock™ LLC be liable to Customer for any indirect, special, or consequential damages, regardless of the circumstances or the cause of action, particularly not for the value of a vehicle, or any other money damages in the event that a tailgate is stolen either notwithstanding the use of a Pop & Lock™ or when it has been returned for repair or replacement.

END OF TERMS AND CONDITIONS

POP & LOCK LLC, 1271 CONTRACT DRIVE, GREEN BAY, WI USA 54304

Additional Install Instructions and answers to technical questions can be found on our website at www.popandlock.net or by calling Technical Support e-mail technicalsupport@popandlock.net or call 1-800-342-5911 option 1.

Pop and Lock's limited warranty expires one (1) year after date of purchase.

Proof of purchase is required for warranty claims. Please submit a scanned copy or electronic image/photo of your receipt through any of the following methods:

- E-mail: technicalsupport@popandlock.net
- Fax: 855-491-5911
- Mail: 1271 Contract Ave, Green Bay, Wisconsin (USA) 54304

Please be sure to include:

- Name, address and phone number
- Model and year of truck
- Model/Part number of the lock
- Brief description of the problem

