



DIESEL DEFENDER INSTALLATION INSTRUCTIONS

FREIGHT DEFENSE



Toll Free: (920) 499-0022 • 1271 Contract Drive - Green Bay, WI 54304 • customerservice@freightdefense.com

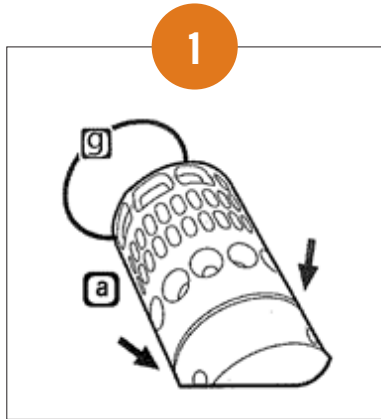

Apply black rubber gasket (g) to the outside of the Diesel Defender (a). The gasket should fit into the indented ring adjacent to the set-screw holes.



Apply metal snap ring (c) to the indented slots near the bottom of the Diesel Defender.

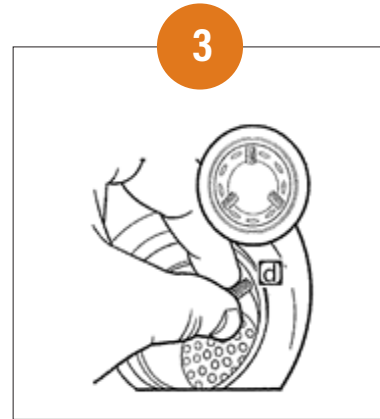

Insert set-screws (d) into the 3 interior holes near the top of the Diesel Defender and tighten by hand not to exceed outer diameter.

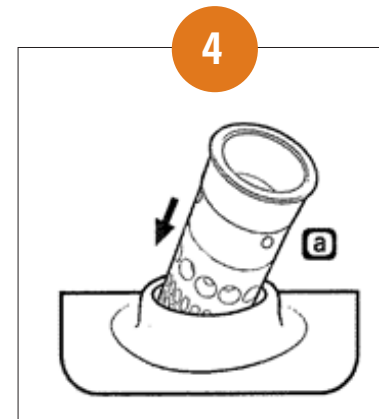

Insert the Diesel Defender (a) into the neck of the diesel fuel tank.

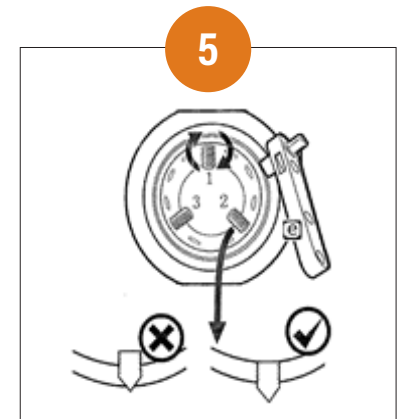

With an optional 1/8" allen wrench or the included toolkit (e), carefully tighten the screws to securely mount the Diesel Defender into the neck of the fuel tank. Be careful not to loosen the set-screws or drop any toolkit accessories into the fuel tank during installation. Tighten set-screws until they are no longer visible within the interior diameter of the Diesel Defender.

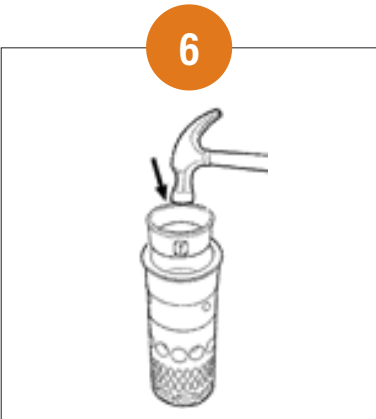

Insert interior cover ring (f) into the inside diameter of the Diesel Defender and tap into place with a hammer.

OPTIONAL

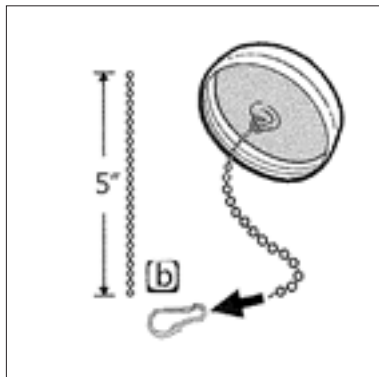

If desired, fasten the metal clip (b) to the fuel cap chain (cap and chain not included).

OPTIONAL

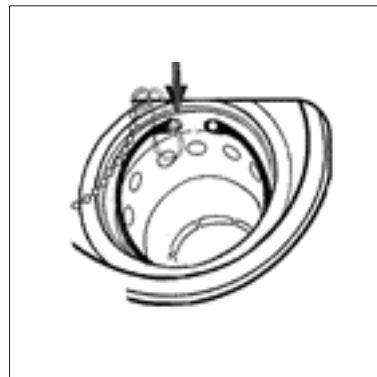

Secure fuel cap chain to the pre-inserted interior ring as shown in the diagram.

Part Number

100246

Volvo (2002 & Older), Mack,
International, Western Star

TECH SUPPORT

Call toll free (855) 935-9999

TOOLS REQUIRED

A hammer and needle nose pliers.

SECURITY FOR THE LONG HAUL